

# VIPER INSTRUCTION SHEET AND WARRANTY

**PLEASE READ & FULLY UNDERSTAND THE INSTRUCTIONS & WARRANTY BEFORE USE**

## INSTALLING YOUR VIPER ESC

### **Positioning of your ESC in the model**

Mount the VIPER ESC as far away as possible from the receiver, using double sided tape or velcro.

Keep the thick power wires from the antenna and other thin wires to avoid interference problems (See Fig.1 for example install).

The antenna should come straight out of the receiver into the antenna tube and up out of the model. Do not attempt to use any part of the model as an antenna!

The ESC should be positioned to allow cooling air to pass over the heatsink fins, this reduces the risk of over-temperature shutdown.

Make sure your motor is fitted with two (2) motor capacitors (0.1uF) - one from the negative terminal to the can and one from the positive terminal to the can.

### **Wiring up of ESC in model (See Fig.1)**

The VIPER ESCs are supplied with Tamiya style plug and bullet connectors at the factory. (Some of the higher powered versions come fitted with solder posts and loose wires.)

### **Colour coding for wires:**

Reversible ESC'S (ECO27, ECO20, RV15, RV11, RV MAX, MARINE15, MARINE20, MARINE25, MARINE40, TRUCK & SSR)

**Black=Batt -ve, Red=Batt +ve, Blue=Mot -ve, Yellow=Mot +ve**

**NOTE: ALWAYS DISCONNECT ESC FROM BATTERY CELLS WHEN NOT IN USE, we recommend fitting an in line fuse in the positive wire between the cells and the ESC. (Usually 5A lower than the ESC's stated limit. eg.. 10A fuse for a 15A ESC)**

### **Receiver Lead Connections**

The receiver lead on the VIPER ESC is the JR type, see chart below. For some receivers you may need to swap the red and brown wires in the plug.

RECEIVER TYPE	SIGNAL	+VE	-VE
	POSITION 1	POSITION 2	POSITION 3
FUTABA, SANWA, KO	White/Blue	Red	Black
HI-TEC	Yellow	Red	Black
JR, GRAUPNER, KYOSHO	White/Orange	Red	Brown
ACOMS	Yellow	Red	Black
AIRTRONICS	White/Orange	Black	Red

**CAUTION! If using an external receiver battery, you must remove the red wire from the ESC's receiver lead first. If using more than one ESC in your model with an external receiver battery you must disconnect the red wire from ALL ESC's. If using more than one ESC in your model without an external receiver battery ensure that only one of the ESC's has the red wire connected. All VIPER ESCs are fitted with 1.2A BEC unless otherwise stated.**

## ESC SET-UP

The Viper Marine15 'Plug n Play' speed control requires no set up! Simply connect your speed control to your battery pack as in fig.1, switch your transmitter on, switch your speed control on with the on/off switch and away you go!

The Plug n Play speed control automatically learns your transmitters settings and adjusts itself to suit as you use it. You don't need to press anything or do anything, just sail away!  
There are no adjustable options on the Plug n Play speed controls to get mixed up with just simply **Plug** it in and **Play!**

**NOTE1: Whichever direction you push the throttle first will be set as the forwards direction.**

**NOTE2: If you have removed the factory fitted battery connector, (see warranty) ensure polarity is correct.**

**NOTE3: If there is a solid red LED this indicates no signal, check transmitter is turned on & that the receiver lead is correctly plugged into the receiver.**

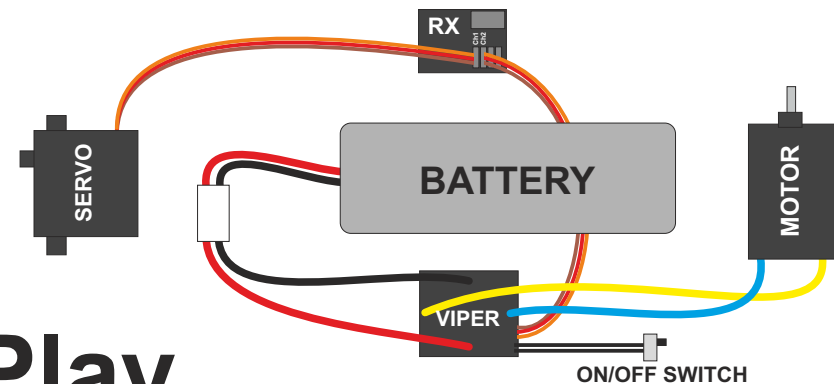

# Plug n Play

Fig.1